

CP COUPLING

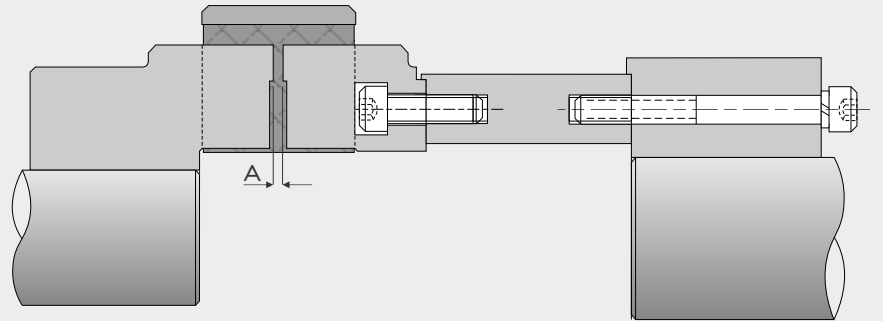

CPS COUPLING

**Installation**

After hubs (1) and (2) and retaining ring (4) are installed on the shaft, the teeth are aligned parallel to each other, spaced apart according to Table 1 below.

Once installed, the hubs never need to be moved again. The Urethane insert (3) can then be installed in the slots formed by the parallel teeth. When the insert is in position, align the pin in the retaining ring with the slot in the insert, slide the retaining ring (4) onto the Urethane insert and tighten the setscrews into the counter-bores in the insert.

Centrifugal force will expand the elastic insert to fit tightly to the inside of the retaining ring, improving system integrity.

To disassemble, loosen the setscrews in the retaining ring and remove the ring. The insert can then be quickly and easily removed and replaced. No special tools are needed.

The assembly and disassembly of the CPS spacer arrangement follow the same procedure with the additional process of securing the spacer to the spacer hub with bolts. The tightening torques for each size are shown in Table 2.



**Table 1**

Coupling Size	Gap Between Teeth Dimension "A"
CP1	1.5
CP2-CP3	2.5
CP4-CP6	3.5
CP7	4
CP8-CP9	5
CP10	6

**Table 2**

Size	Tightening Torque	
	Nm	lb2in
CPS1	19	170
CPS2	19	170
CPS3	54	480
CPS4	100	800
CPS5	100	800
CPS6	230	2000