



# S145Z / S145ZQ

Single Cartridge Seal

### Materials

- Stationary - Car / SiC / SSiC / TC
- Rotary - SiC / SSiC / TC
- Elastomer - NBR / EPDM / Viton / Aflas / FFKM

### Working Conditions

- Pressure < 28 bar
- Speed < 25 bar
- Temperature up to 205 C

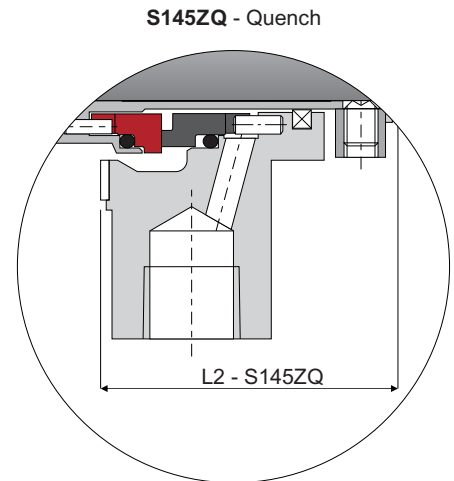
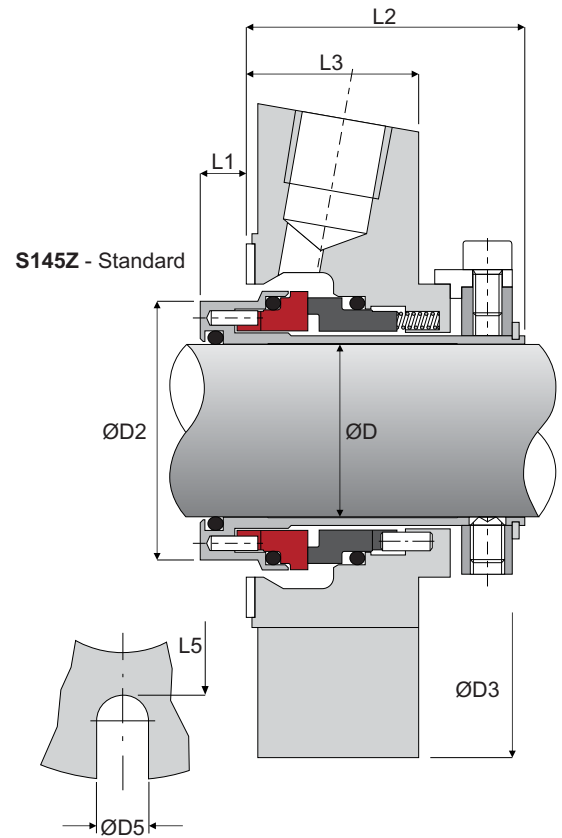

Sha? Size ØD		ØD2	ØD3	ØD5	L1	L2		L3	L5
Inches	mm					S145Z	S145ZQ		
1.000	25	40	104	12.5	8	49	55	30	62
1.125	28	43	104	12.5	8	49	55	30	62
1.250	30	45	104	12.5	8	49	55	30	67
	32	47	104	12.5	8	49	55	30	67
	33	47	104	12.5	8	49	55	30	67
1.375	35	50	110	12.5	8	49	55	30	70
1.500	38	53	125	14.7	8	49	55	30	75
1.625	40	55	125	14.7	8	49	55	30	75
	42	57	133	14.7	8	49	55	30	80
	43	58	133	14.7	8	49	55	30	80
1.750	45	60	140	14.7	8	49	55	30	82
1.875	48	63	140	14.7	8	49	55	30	82
2.000	50	65	140	14.7	8	49	55	30	87
2.125	53	68	150	17.5	8	49	55	30	92
	55	70	150	17.5	8	49	55	30	92
2.250	58	73	155	17.5	8	49	55	30	100
2.375	60	75	160	17.5	8	49	55	30	100
2.500	63	Use Standard S145 Seal for ANSI Stuffing Box							
2.625	65								
2.750	70								

**Gasket Sizes**  
 <73mm ID = ØD2 + 2.5mm  
 OD = L5 - 1.5mm  
 73mm ID = ØD2 + 3mm  
 OD = L5 - 1.5mm