



S171

Single Cartridge Seal

Materials

- Stationary - Car / SiC / SSiC / TC
- Rotary - SiC / SSiC / TC
- Elastomer - NBR / EPDM / Viton / Aflas / FFKM

Working Conditions

- Pressure < 28 bar
- Speed < 25 m/s
- Temperature up to 205°C

Features:

- Stationary Design
- Monolithic Faces
- Cushioned Faces
- Pressure balanced
- Springs outside the media

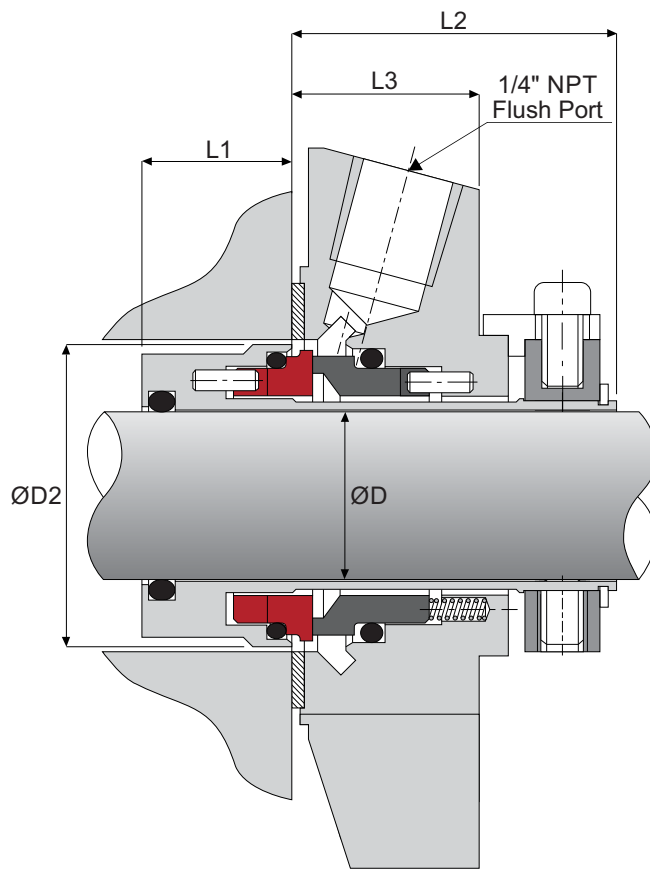

Gasket Sizes

- ID = ØD2 + 2.5mm
- OD = L5 - 1.5mm

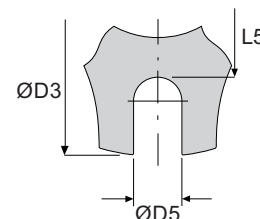

Inch ØD	Code	ØD2		ØD3		ØD5		L1		L2		L3		L5	
		mm	inch	mm	inch	mm	inch	mm	inch	mm	inch	mm	inch	mm	inch
1.000	0254	39.9	(1.571)	105	(4.134)	12.5	(0.492)	18	(0.709)	38	(1.496)	21.5	(0.846)	62	(2.441)
1.125	0286	43.1	(1.697)	105	(4.134)	12.5	(0.492)	18	(0.709)	38	(1.496)	21.5	(0.846)	62	(2.441)
1.250	0317	46.3	(1.823)	105	(4.134)	12.5	(0.492)	18	(0.709)	38	(1.496)	21.5	(0.846)	65	(2.559)
1.375	0349	49.5	(1.949)	105	(4.134)	12.5	(0.492)	18	(0.709)	38	(1.496)	21.5	(0.846)	67	(2.638)
1.500	0381	55.3	(2.177)	115	(4.528)	12.5	(0.492)	18	(0.709)	38	(1.496)	21.5	(0.846)	70	(2.756)
1.625	0412	58.3	(2.295)	125	(4.921)	14.7	(0.579)	18	(0.709)	38	(1.496)	21.5	(0.846)	75	(2.953)
1.750	0444	62.3	(2.453)	133	(5.236)	14.7	(0.579)	18	(0.709)	38	(1.496)	21.5	(0.846)	80	(3.150)
1.875	0476	65.3	(2.571)	140	(5.512)	14.7	(0.579)	18	(0.709)	38	(1.496)	21.5	(0.846)	81	(3.189)
2.000	0508	68.5	(2.697)	140	(5.512)	14.7	(0.579)	18	(0.709)	38	(1.496)	21.5	(0.846)	84	(3.307)
2.125	0539	71.5	(2.815)	150	(5.906)	17.5	(0.689)	18	(0.709)	38	(1.496)	21.5	(0.846)	92	(3.622)
2.250	0572	76.5	(3.012)	160	(6.299)	17.5	(0.689)	19	(0.748)	38	(1.496)	21.5	(0.846)	100	(3.937)
2.375	0603	78.5	(3.091)	160	(6.299)	17.5	(0.689)	19	(0.748)	38	(1.496)	21.5	(0.846)	100	(3.937)
2.500	0635	81.5	(3.209)	165	(6.496)	17.5	(0.689)	19	(0.748)	38	(1.496)	21.5	(0.846)	109	(4.291)
2.625	0666	86.52	(3.406)	165	(6.496)	17.5	(0.689)	19	(0.748)	38	(1.496)	21.5	(0.846)	109	(4.291)